



INSTALLATION INSTRUCTIONS

MSD Digital SCI+ Ignition Control, PN 6350

Parts Included:

- 1 - MSD Ignition
- 1 - Harness, PN 8860
- 1 - Parts Bag, ASY19864

WARNING: During installation, disconnect the battery cables. When disconnecting the battery always remove the Negative cable first and install it last.

Note: Solid Core spark plug wires cannot be used with an MSD Ignition.

OPERATION AND FEATURES

DIGITAL OPERATION

The MSD Digital SCI+ uses a high speed RISC microcontroller to control the ignition's output while constantly analyzing the various inputs such as supply voltage, trigger signals and rpm. The high speed controller can make extremely quick compensations to the output voltage, multiple spark series, timing and rpm limits while maintaining accurate timing signals to within 1° and 1% of the rpm limits. The circuits and controller of the Digital SCI+ have been thoroughly debounced and isolated to create protection against Electro Magnetic Interference (EMI).

CAPACITIVE DISCHARGE

The MSD SCI+ features a capacitive discharge ignition design. The majority of stock ignition systems are inductive ignitions. In an inductive ignition, the coil must store and step up the voltage to maximum strength in between each firing. At higher rpm, since there is less time to charge the coil to full capacity, the voltage falls short of reaching maximum energy which results in a loss of power or top end miss.

The MSD Ignition features a capacitor which is quickly charged with 520 - 535 volts and stores it until the ignition is triggered. With the CD design, the voltage sent to the coil is always at full power even at high rpm.

MULTIPLE SPARKS

The MSD produces full power multiple sparks for each firing of a plug. The number of multiple sparks that occur decreases as rpm increases, however the spark series always lasts for 20° of crankshaft rotation. Above 3,300 rpm there is simply not enough "time" to fire the spark plug more than once, so there is only one powerful spark.

PROTECTION

The MSD Digital SCI+ has a built in reverse polarity protection circuit. This will protect the ignition in the event of wrong connections. It will also shut off for protection from a surge in power. The ignition will still operate once the surge or polarity is corrected.

LED INDICATOR

There is an LED that monitors the status of the Ignition. The LED monitors several parameters of the ignition including trigger signal, low voltage and high voltage.

HOLESHOT REV CONTROL

The Digital SCI+ Ignition Control features a built-in Holeshoot Rev Control. This feature allows you to set a rev limit that can be activated on the starting line to hold the engine at a steady rpm resulting in improved and consistent launches. The rpm limit is adjusted in 100 rpm increments with the sealed rotary switches on the side of the ignition.

To activate this rpm limit, 12 volts must be applied to the Blue wire. For example, by connecting this wire to the line-lock switch, the rev limit will be activated with the line-lock. When the line-lock is released for the launch, the rpm limit will be deactivated as well.

RETARD CONTROL

There is a single stage of retard that can be adjusted from 0 to 9.9 degrees in 1/10° increments. The retard is activated when the Pink wire receives 12 volts which is explained on page 6.

START RETARD

To ease starting on engines with locked out timing, there is a Start Retard circuit. When set, the timing will be retarded 20° until the engine reaches over 800 rpm. Activating the Start Retard is done with the Cylinder Select dial and is explained on page 5.

CYLINDER SELECT

The MSD is programmed at the factory for use on 4-cylinder engines. If you are installing it to a different engine you will have to program the Ignition. This is easily achieved through the cylinder select switch on the side of the ignition. Page 5 outlines setting the cylinder select.

GENERAL INFORMATION

BATTERY

The MSD Digital SCI+ Ignition Control will operate on any negative ground, 12 volt electrical system with a distributor. The MSD can be used with 16 volt batteries and can withstand a momentary 24 volts in case of jump starts. The Ignition will deliver full voltage with a supply of 9 - 18 volts and will operate with a supply voltage as low as six volts.

If your application does not use an alternator, allow at least 15 amp/hour for every half hour of operation. The MSD uses about .7 Amps for every 1,000 rpm. If the engine is cranked with the same battery or other accessories such as an electric fuel or water pump are used, the amp/hour rating should be higher.

COILS

The MSD Digital SCI+ Ignition Control can be used with most stock coils and aftermarket coils designed to replace the stock coils. The line of MSD Blaster Coils are great for street and mild racing. For extended high rpm operation the Blaster HVC, PN 8252 or Blaster HVC 2, PN 8253, are recommended. For more information on recommended coils, consult the supplied Coil Application Chart or check with our Customer Service Department at (915) 855-7123.

TACHOMETERS

The MSD Ignition features a Tach Output Terminal on the side of the unit (Figure 1). This terminal provides a trigger signal for tachometers, a shift light or other add-on rpm activated devices. The Tach Output Terminal produces a 12 volt square wave signal with a 30° duty cycle.

Some vehicles with factory tachometers may require a Tach Adapter to operate with the MSD. For more information on Tachometers and MSD Tach Adapters, see the Tachometer Section on page 8.

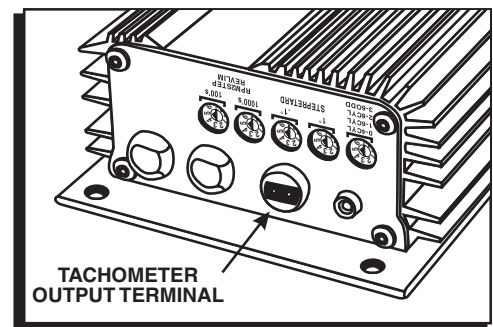

Figure 1 Tach Terminal

SPARK PLUGS AND WIRES

Spark plug wires are very important to the operation of your ignition system. A good quality, helically wound wire and proper routing are required to get the best performance from your ignition, such as the MSD Heli-Core or 8.5mm Super Conductor Wire. Helically wound wires provide a good path for the spark to follow while keeping Electro Magnetic Interference (EMI) to a minimum. Excessive EMI, such as the amount that solid core wires produce, will interfere with the operation of the MSD. **Solid Core spark plug wires cannot be used with an MSD Ignition.**

Routing: Correct routing of the plug wires is also important to performance. Wires should be routed away from sharp edges and engine heat sources. If there are two wires that are next to each other in the engine's firing order, the wires should be routed away from each other to avoid inducing a spark into the other wire.

To add more heat protection to your plug wires, MSD offers Pro-Heat Guard, PN 3411. This is a glass woven and silicone coated protective sleeve that you slide over your plug wires. For extra protection of the spark plug boots, MSD offers Pro-Heat Boot Guard, PN 3412.

Spark Plugs: Choosing the correct spark plug design and heat range is important when trying to get the best performance possible. Since there are so many engine combinations and manufacturers, MSD does not recommend which plug or gap is exactly right for your application. It is recommended to follow the engine builder or manufacturer's specification for spark plugs. With that, you can then experiment with the plug gap to obtain the best performance. The gap of the plugs can be opened in 0.005" increments, then tested until the best performance is obtained. MSD judges the plug gap by compression and components.

Sealing: The MSD is potted completely with a polyurethane compound for vibration and water resistance. The programming rotary switches are sealed as well.

Welding: If you are welding on your vehicle, to avoid the chance of damage, always disconnect both Heavy Power cables of the MSD. (You should also disconnect the tach ground wire too).

Distributor Cap and Rotor: It is recommended to install a new distributor cap and rotor when installing the MSD Ignition Control. The cap should be clean inside and out especially the terminals and rotor tip. On vehicles with smaller caps, it is possible for the air inside the cap to become electrically charged causing crossfire which can result in misfire. This can be prevented by drilling a couple vent holes in the cap. The holes should be placed between the terminals, at rotor height and face away from the intake. If your environment demands it, place a small piece of screen over the hole to act as a filter.

MOUNTING

The MSD can be mounted in the engine compartment as long as it is away from direct engine heat sources. It is not recommended to mount the unit in an enclosed area such as the glovebox.

When you find a suitable location to mount the unit, make sure the wires of the ignition reach their connections. Also be sure that the program dials can be accessed. Hold the Ignition in place and mark the location of the mounting holes. Use an 1/8" bit to drill the holes or, if using the supplied vibration mounts, use a 3/16" bit and mount the ignition.

WIRING

WIRE FUNCTIONS

Power Leads	These are the two heavy 12 gauge wires and are responsible for getting direct battery voltage to the ignition. The Ignition is load protected from reverse battery connections and will automatically shut down if there is over 27 volts input.
Heavy Red	This wire connects directly to the battery positive (+) terminal or a positive battery junction such as the starter solenoid. Note: Do not connect to the alternator.
Heavy Black	This wire connects to a good ground, either at the battery negative (-) terminal or to the engine.
Red	This wire is responsible for turning the MSD On and Off. Connects to a switched 12 volt source such as the ignition key or switch.
Orange	This wire connects to the coil positive (+) terminal. This is the ONLY wire that makes electrical contact with the positive coil terminal.
Black	This wire connects to the coil negative (-) terminal. This is the ONLY wire that makes electrical contact with the negative coil terminal.
Trigger Wires	There are two circuits that can be used to trigger the MSD Ignition; a Points circuit (the White wire) and a Magnetic Pickup circuit (the Green and Violet wires). The two circuits will never be used at the same time.
White	This wire is used to connect to breaker points, electronic ignition amplifier output or to the Yellow wire of an MSD Timing Accessory. When this wire is used, the Magnetic Pickup connector is not used.
Violet and Green (Magnetic Pickup Connector)	These wires are routed together in one harness as the magnetic pickup connector. The connector plugs directly into an MSD distributor or crank trigger. It will also connect to aftermarket pickups. The Violet wire is positive (+) and the Green wire is negative (-). When these wires are used, the White wire is not.
Green Loop	This wire loops out of the strain relief. It is used to compensate for different magnetic pickups. The MSD is set up to be used with GM and MSD crank triggers. If you are installing the ignition with an MSD Distributor or Ford Distributor, this Loop should be cut and sealed. Note: No cutting is necessary when triggering with the White wire.
Accessories	
Blue	This wire activates the Holeshot Rev Control. When 12 volts is applied to this wire, the Holeshot rpm limit is activated. When 12 volts is removed, there is no limit.
Pink	This wire activates the retard stage when it is applied to 12 volts. When 12 volts is removed the retard is deactivated.

GENERAL WIRING INFORMATION

Wire Length: All of the wires of the MSD Ignition may be shortened as long as quality connectors are used or soldered in place. To lengthen the wires, use one size bigger gauge wire (10 gauge for the power leads and 16 gauge for the other wires) with the proper connections. All connections must be soldered and sealed.

Grounds: A poor ground connection can cause many frustrating problems. When a wire is specified to go to ground, it should be connected to the battery negative terminal, engine block or chassis. There should always be a ground strap between the engine and the chassis. Always securely connect the ground wire to a clean, paint free metal surface.

Ballast Resistor: If your vehicle has a ballast resistor in line with the coil wiring, it is not necessary to bypass it. This is because the MSD receives its main power directly from the battery.

Routing Wires: The MSD wires should be routed away from direct heat sources such as exhaust manifolds and headers and any sharp edges. The trigger wires should be routed separate from the other wires and spark plug wires. It is best if they are routed along a ground plane such as the block or firewall which creates an electrical shield. The magnetic pickup wires should always be routed separately and should be twisted together to help reduce extraneous interference.

PROGRAMMING

CYLINDER SELECT

The MSD is programmed for operation on 4-cylinder engines. If installing the Ignition on a different style engine, the number of cylinders will need to be selected on the Cylinder Select Rotary Switch (Figure 2).

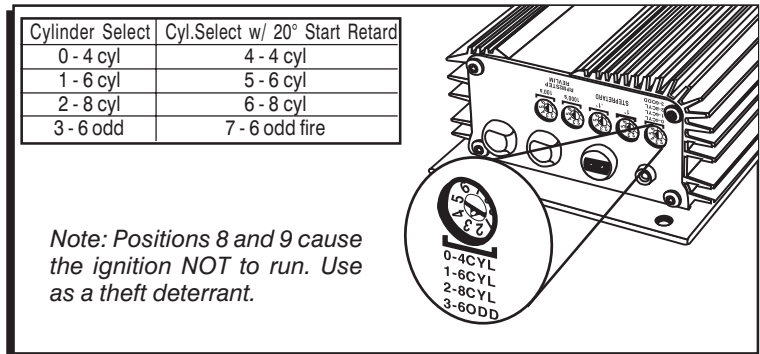

Figure 2 Programming the Number of Cylinders.

START RETARD

The Start Retard will be activated during cranking only when the Cylinder Select dial is in the 4, 5, 6 or 7 position (Figure 2). During cranking the timing will retard 20° until 800 rpm when it returns to the mechanical setting. If engine speed drops below 500 rpm, the start retard is activated again.

MAGNETIC PICKUP COMPENSATION

Note: If your application uses the MSD's White wire for the trigger input, the magnetic compensation circuit is not used.

The Green wire loop of the MSD provides a timing compensation for different style trigger pickups. Having the ability to program for the style pickup being used provides a more accurate timing signal. This compensation is used primarily with crank trigger or locked out timing applications. The Digital MSD is programmed at the factory for use with an MSD Crank Trigger or GM magnetic pickup. If you are using an MSD Billet Distributor or the magnetic pickup of a Ford or Chrysler distributor the Green Loop should be cut and sealed (Figure 3).

Note: It is recommended to check your total timing to ensure the setting for your application.

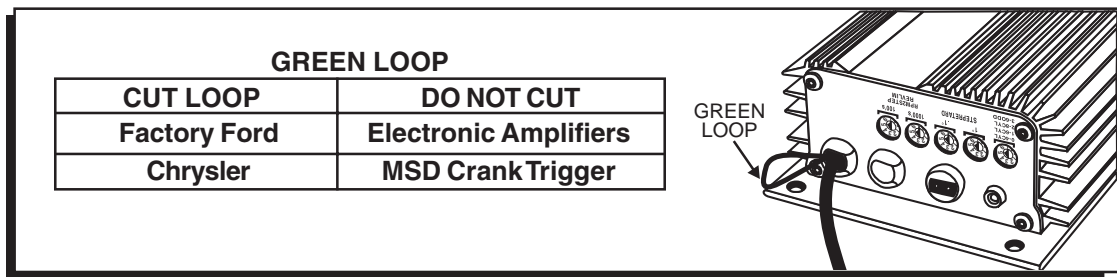

Figure 3 Programming the Compensation Circuit.

HOLESHOT REV CONTROL

The Holeshoot Rev Limit is activated only when 12 volts are applied to the Blue wire. This limit is adjustable from 2,000 to 9,900 in 100 rpm increments with the rotary switches shown in Figure 4. The rpm limit will default to 2,000 rpm if the switches are set below this range. The example shown in Figure 4 shows wiring the Holeshoot Rev Control to a Line-Lock Switch.

Note: The engine can be running as changes are made to the Holeshoot Rev Limit.

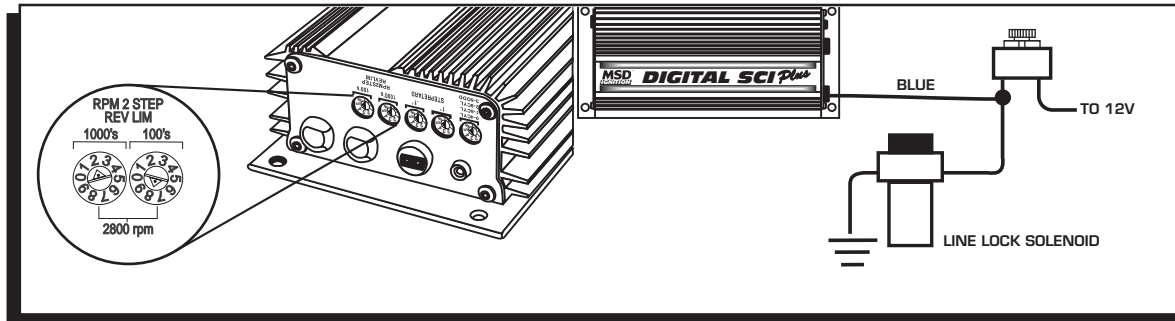

Figure 4 Wiring and Adjusting the 2-Step Rev Limit.

RETARD STAGE

The MSD features a single stage retard step that is activated when 12 volts are applied to the Pink wire. The retard will remain until the 12 volts are removed. This retard step can be connected to a nitrous solenoid activation wire or micro-switch on the shifter. The retard is adjustable from 0° to 9.9° in 1/10° increments. The example in Figure 5 shows connecting the retard to a nitrous stage.

Note: This retard will only operate above 2,000 rpm.

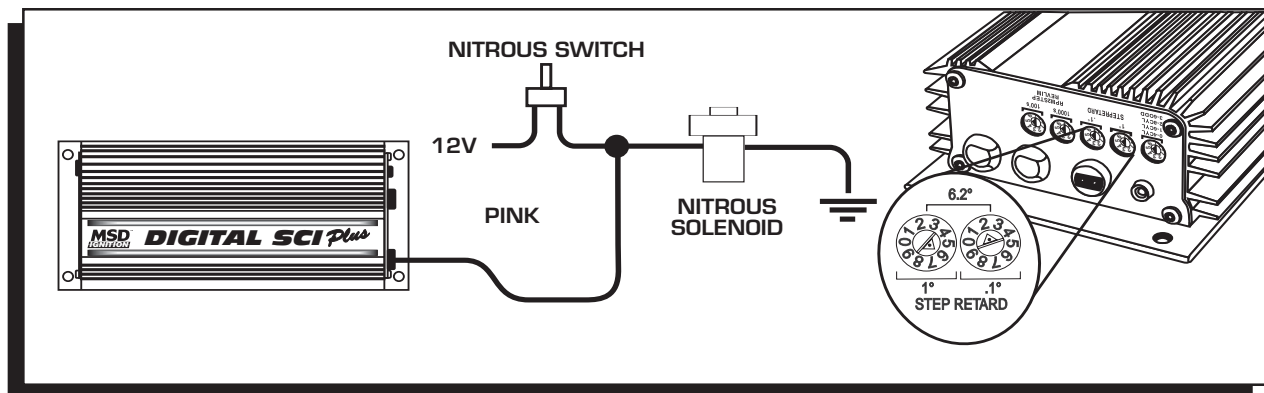

Figure 5 Wiring the Retard Stage.

PRESTART CHECK LIST

- The only wires connected to the coil terminals are the MSD Orange to coil positive and Black to coil negative.
- The small Red wire of the MSD is connected to a switched 12 volt source.
- Confirm the cylinder select is in the proper position for your application.
- The MSD power leads are connected directly to the battery positive and negative terminals.
- The battery is connected and fully charged if not using an alternator.
- The engine is equipped with at least one ground strap to the chassis.

TROUBLESHOOTING

Every MSD Ignition undergoes numerous quality control checks including a four hour burn-in test. If you experience a problem with your MSD, our research has shown that the majority of problems are due to improper installation or poor connections.

The Troubleshooting section has several checks and tests you can perform to ensure proper installation and operation of the MSD. If you have any questions concerning your MSD, call our Customer Support Department at (915) 855-7123, 8 - 5 mountain time.

LED

The LED on the side of the MSD monitors several operating conditions of the MSD. If the LED indicates that there is a problem with the ignition system, follow the steps through the Troubleshooting section. The LED will appear to be on steady at above idle speeds when everything is functioning properly.

- Flashes once per second if the battery supply voltage is low when under 3,300 rpm (while multiple sparking). This indicates a charging problem or poor connection.
- It will flash approximately once per second if the battery input voltage is above 27 volts for a sustained amount of time.
- The LED will flash for every trigger signal from the distributor or crank trigger. You can take advantage of this when statically setting the timing when using the White wire to trigger.

INSTALLATION CONDITIONS

Depending on the installation and the vehicle wiring, there are three possible conditions that may arise when installing the MSD Digital-SCI+ Ignition Control to your sport compact. They are; Inoperative Tach, Check Engine Light, No-Run or Start/Stall. Any of these problems can easily be fixed with an MSD Tach/Fuel Adapter.

There are three Adapters available depending on your vehicle and how the MSD Ignition is being triggered. Due to the variety of vehicle systems produced, MSD cannot list every application. Following are some general tips and suggestions.

TACHOMETER AND CHECK ENGINE LIGHT

If the tachometer does not work, or fluctuates a Tach Adapter will fix the problem. The factory tach may not be able to distinguish the signal of the Digital SCI+ Ignition. Before purchasing an Adapter, it is recommended to route the tach's trigger wire to the Tach Output terminal on the side of the MSD unit. This terminal produces a 12 volt square wave signal and will trigger most voltage triggered tachs. If the tach still does not operate correctly, see the chart in Figure 6 for the correct Tach Adapter.

No Run or Start/Stall

Some sport compact vehicles may experience a no-run or start-stall situation after installing the MSD. This is because many of these systems use the same trigger source to operate the MSD and the fuel injection. In a few cases, connecting the MSD may result in a weaker voltage signal that may not be able to accurately trigger the EFI. The MSD PN 8910 or PN 8910-EIS Tach Adapter will boost this signal and correct the condition.

Note: Most applications that use the White wire to trigger the MSD will use the PN 8910 Adapter.
Most Toyotas and Ford Probes will use the PN 8910-EIS Adapter.

Engine Run-On:

This is a rare problem that may occur on older vehicles with an external voltage regulator and carbureted engine. The MSD can receive a feedback from the charging lamp indicator in the dash which is enough to keep the MSD turned on. A diode is supplied in the parts bag that will need to be installed on the wire leading to the charging indicator.

Tachometer Compatibility List

AFTERMARKET TACHOMETER	WHITE WIRE TRIGGER	MAGNETIC TRIGGER CONNECTOR
AUTOGAGE	8910	8920
AUTOMETER	NONE	NONE
FORD MOTORSPORTS	NONE	NONE
STEWART	8910	8920
S.W. & BITORX	NONE	NONE
SUN	8910	8920
VDO	NONE	NONE
CHRYSLER	8910	8920
FORD (After 1976)	8910	8920

Note: On the list above, the trigger wire on tachometers that are marked NONE may be connected to the Tach Output Terminal on the MSD 6 Series Ignition Unit using the supplied Female Faston Receptacle.

Figure 6 Common Tachometers and Adapters.

MISSES AND INTERMITTENT PROBLEMS

Experience at the races has shown that if your engine is experiencing a miss or hesitation at higher rpm, it is usually not directly ignition. Most probable causes include faulty wiring, a coil or plug wire failure, arcing from the cap or boot plug to ground or spark ionization inside the cap. Several items to inspect are:

- Always inspect the plug wires at the cap and at the plug for a tight connection and visually inspect for cuts, abrasions or burns.
- Inspect the Primary Coil Wire connections. Because the MSD is a Capacitive Discharge ignition and it receives a direct 12 volt source from the battery, there will not be any voltage at the Coil Positive (+) terminal even with the key turned On. During cranking or while the engine is running, very high voltage will be present and no test equipment should be connected.

WARNING: Do not touch the coil terminals during cranking or while the engine is running.

- Make sure that the battery is fully charged and the connections are clean and tight. If you are not running an alternator this is an imperative check. If the battery voltage falls below 9 volts during a race, the MSD output voltage will drop and the current draw will increase.
- Is the engine running lean? Inspect the spark plugs and complete fuel system.
- Inspect all wiring connections for corrosion or damage. Remember to always use proper connections followed by soldering and seal the connections completely.

If everything checks positive, use the following procedure to test the ignition for spark. MSD also offers an Ignition Tester, PN 8998. This tool allows you to check your complete ignition system while it is in the car as well as the operation of rpm limits, activated switches and shift lights.

CHECKING FOR SPARK

If triggering the ignition with the White wire:

1. Make sure the ignition switch is in the "Off" position.
2. Remove the coil wire from the distributor cap and set the terminal approximately 1/2" from ground.
3. Disconnect the MSD White wire from the distributor's points or ignition amplifier.
4. Turn the ignition to the On position. Do not crank the engine.
5. Tap the White wire to ground several times. Each time you pull the wire from ground, a spark should jump from the coil wire to ground. If spark is present, the ignition is working properly. If there is no spark skip to step 6.

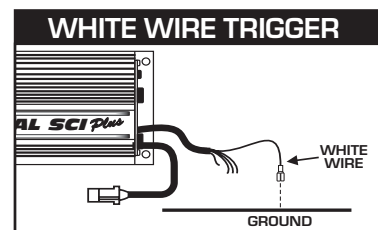

Figure 7 Checking for Spark with the White Wire.

If triggering with the Magnetic Pickup:

1. Make sure the ignition switch is in the "Off" position.
2. Remove the coil wire from the distributor cap and set the terminal approximately 1/2" from ground.
3. Disconnect the MSD magnetic pickup wires from the distributor.
4. Turn the ignition to the On position. Do not crank the engine.
5. With a small jumper wire, short the MSD's Green and Violet magnetic pickup wires together several times. Each time you break this short, a spark should jump from the coil wire to ground. If spark is present, the ignition is working properly. If there is no spark skip to step 6 below:

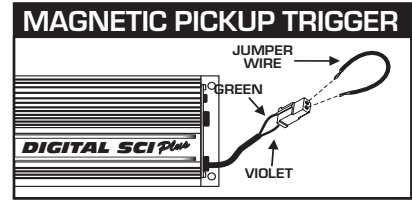
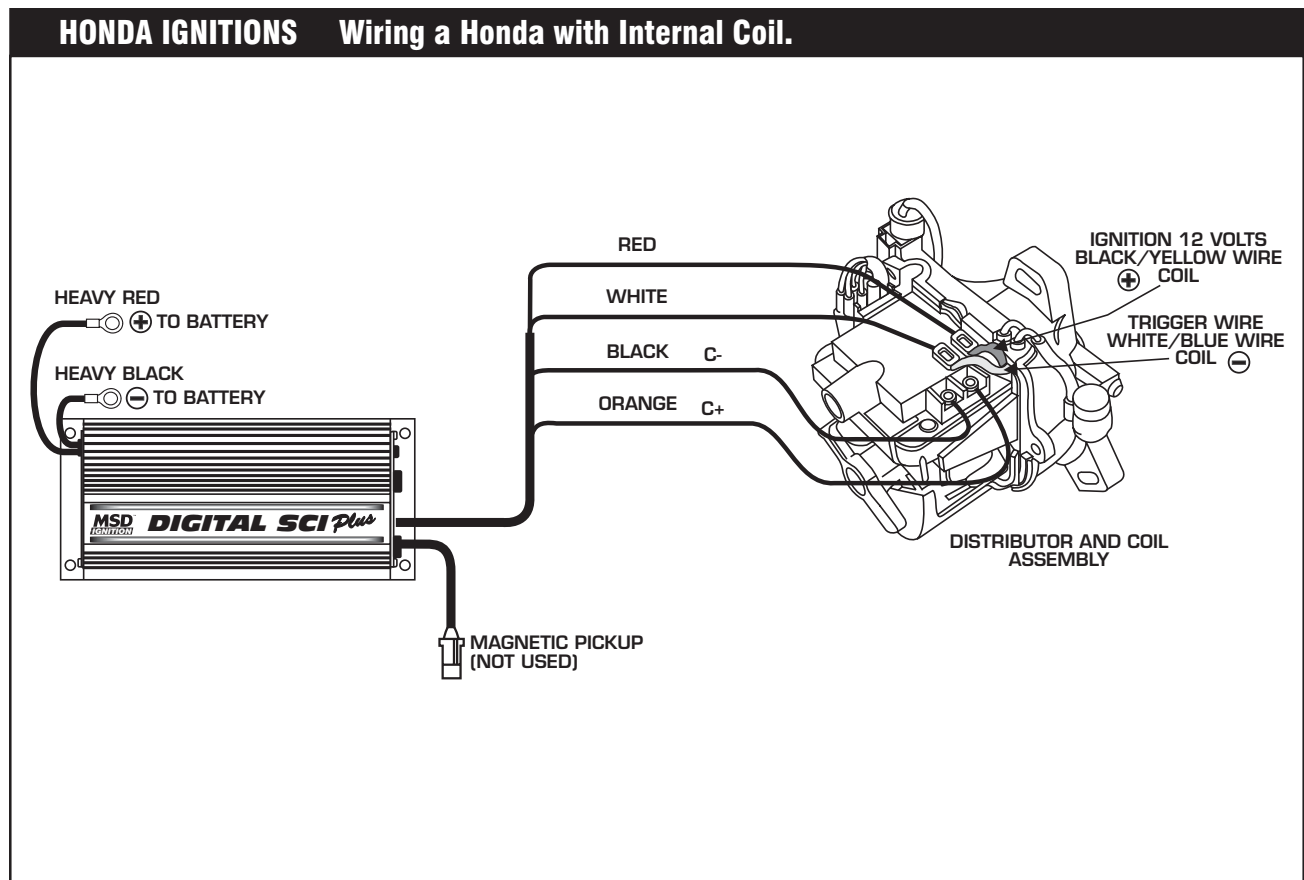

Figure 8 Checking for Spark with the Mag Pickup.

6. If there is no spark:
 - A. Inspect all of the wiring.
 - B. Substitute another coil and repeat the test. If there is now spark, the coil is at fault.
 - C. If there is still no spark, check to make sure there are 12 volts on the small Red wire from the MSD when the key is in the On position. If 12 volts are not present, find another switched 12 volt source and repeat the test.
 - D. If, after following the test procedures and inspecting all of the wiring, there is still no spark, the MSD Ignition is in need of repair. See the Warranty and Service section for information.

The following wiring diagrams illustrate numerous installations on different vehicles and applications. If you experience difficulties when installing your MSD, contact our Customer Support Department at (915) 855-7123 (8 - 5 Mountain time) or e-mail us at: msdtech@msdignition.com



HONDA IGNITIONS Wiring a Honda with an external coil.

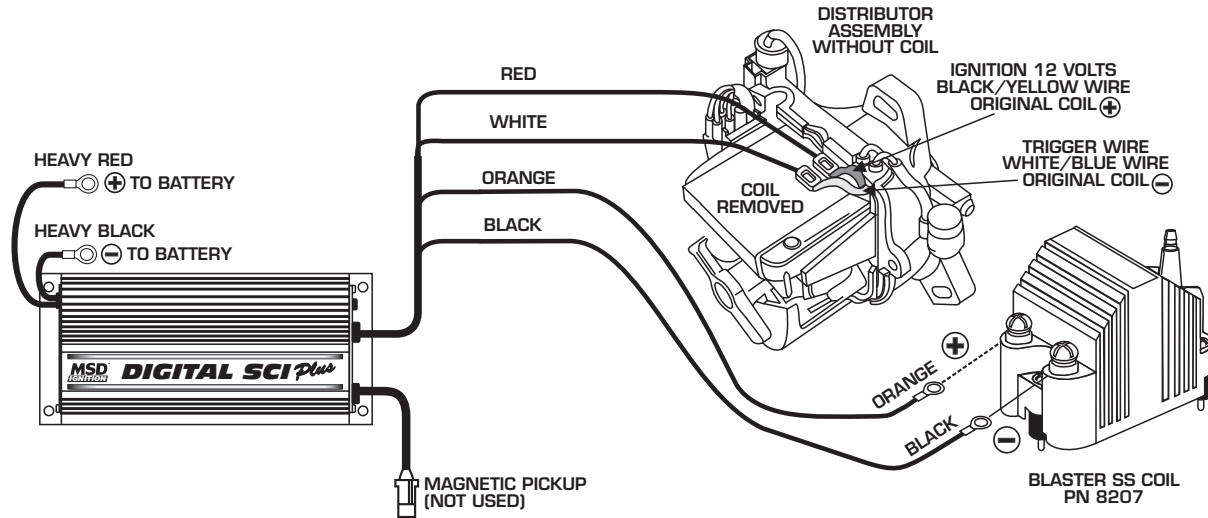

HONDA IGNITIONS with Boost Timing Control.

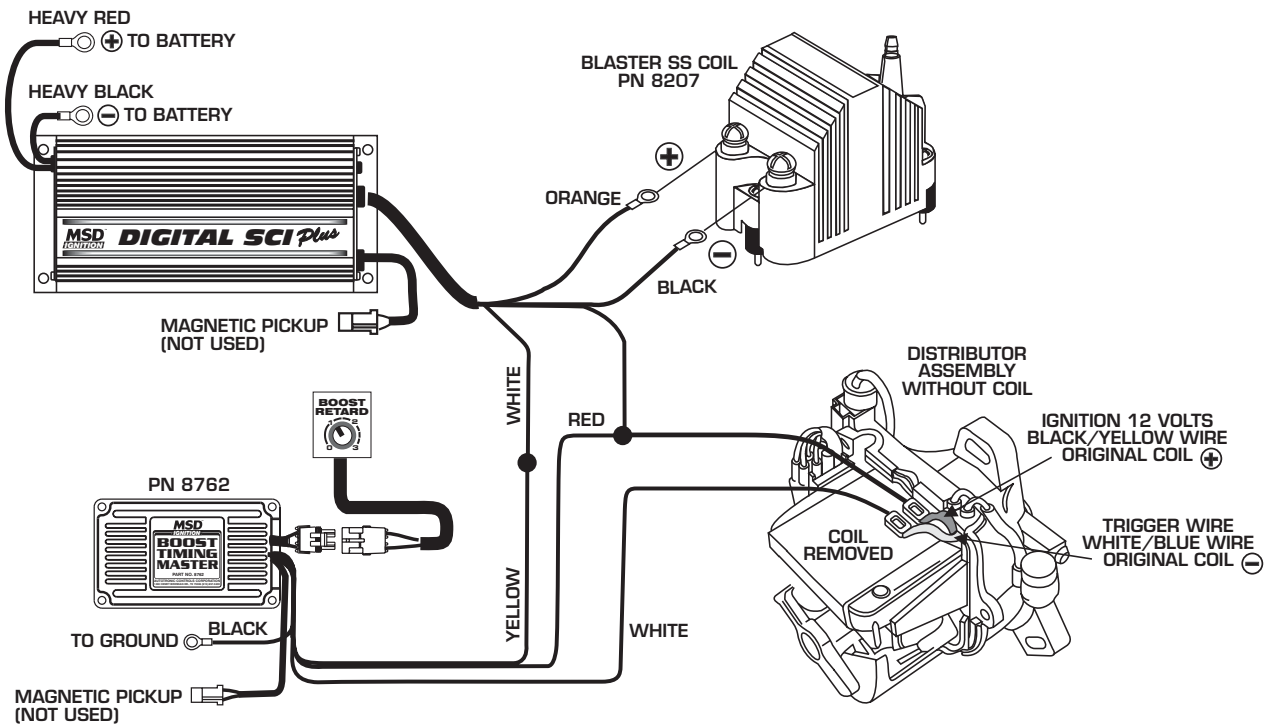

GENERAL IMPORT WIRING

NOTE: Remove the coil terminal wires. The negative wire connects to MSD White. The positive wire connects to MSD Red. The MSD Orange connects to the coil positive terminal, Black connects to the coil negative terminal.

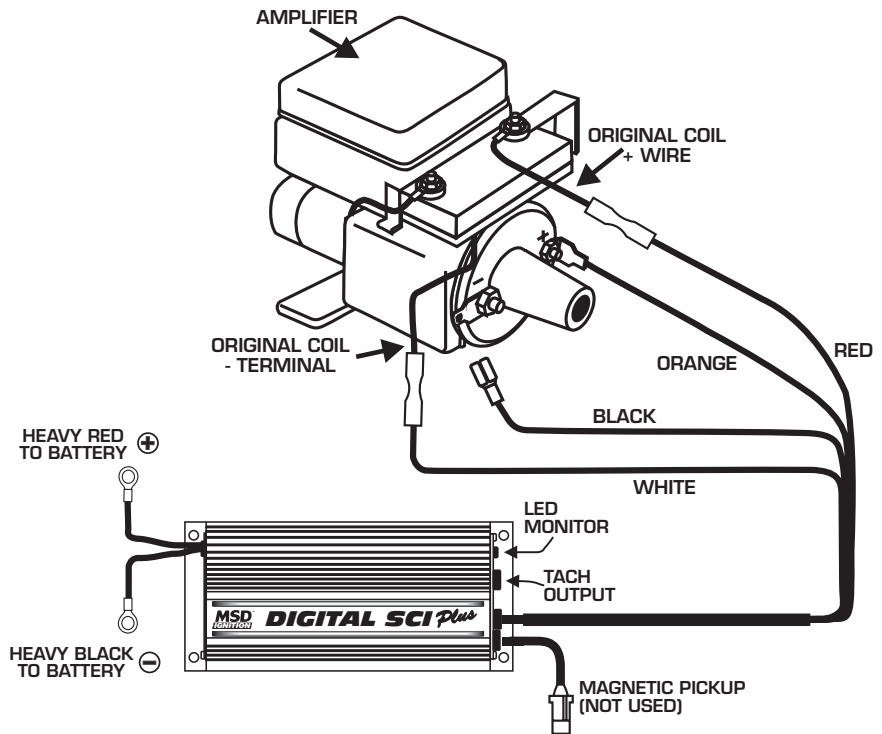

MSD SYSTEMS Installing to an MSD Distributor/Crank Trigger.

